

EVOLo 631 DIVIDED SPINDLE GRADE A-F

APPLICATION

Optimum vibration isolation for a wide range of applications. For larger, heavy-weighted equipment under extreme conditions that needs optimal vibration isolation at both high and low frequencies, such as generator sets, pump units, large diesel engines, compressor/cooling units, gear boxes, windmills, deck house mountings, control cabins.

MATERIAL

Rubber part: Highest quality natural rubber
 Metal: Aluminum/Steel

IDENTIFICATION

The type is marked in the mounting plate.

ADVANTAGES

- Type approvals available on request
- Optimum vibration isolation
- Easy and quick installation
- Build in end-limiter to protect against overload
- Capable of handling both vertical and horizontal forces
- Natural rubber gives maximum vibration isolation
- One type fits all weights between 1000 and 6000 kg
- Stock item



TECHNICAL DRAWING

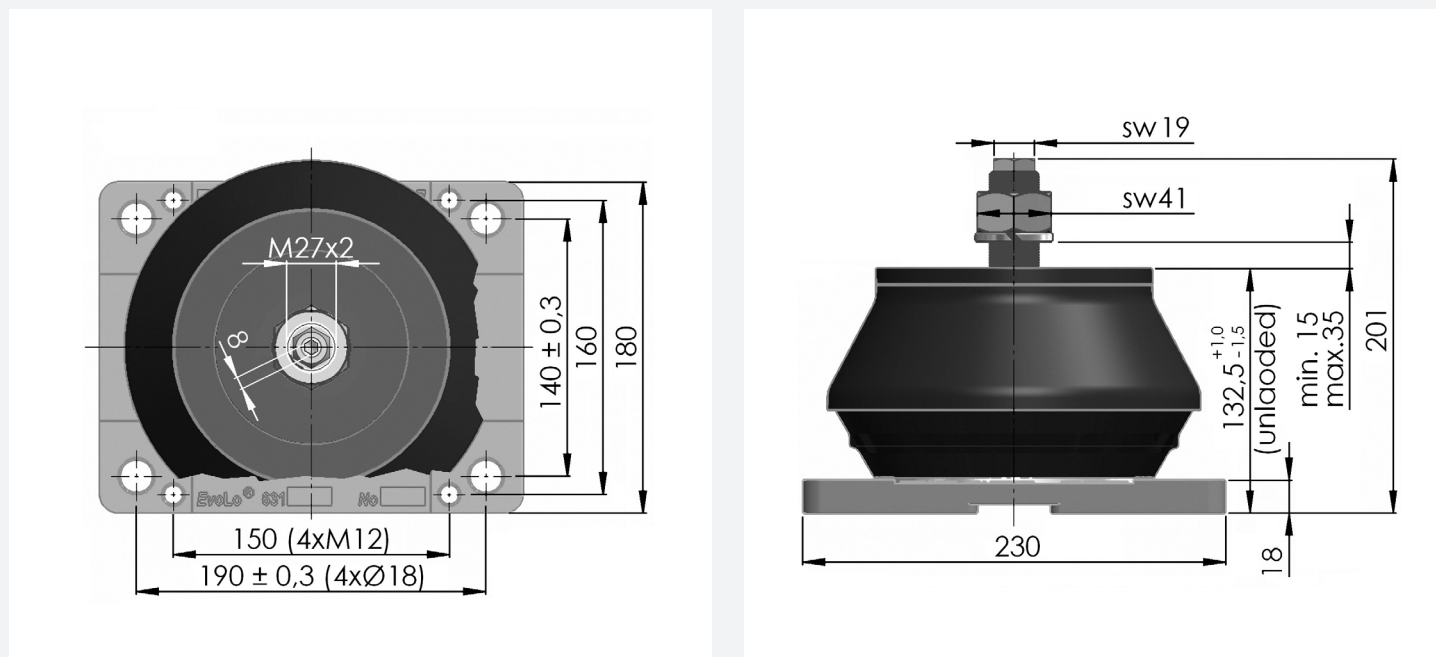

EVOLO 631 DIVIDED SPINDLE GRADE A-F

TECHNICAL DATA

ARTICLE NO.	GRADE	MAXIMUM LOAD
1030631A4	A	60 kN
1030631B4	B	50 kN
1030631C4	C	40 kN
1030631D4	D	33 kN
1030631E4	E	23 kN
1030631F4	F	17 kN

STATIC VERTICAL CHARACTERISTICS

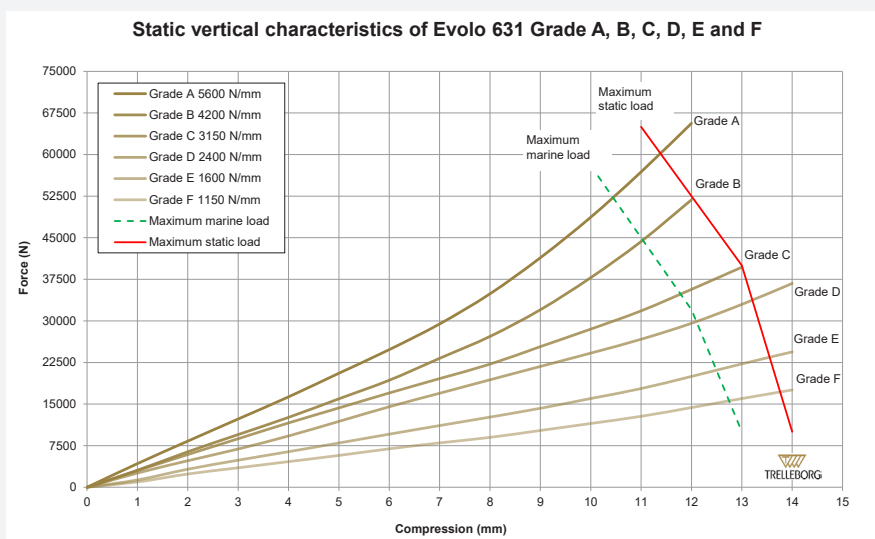

HORIZONTAL CHARACTERISTICS WHEN PRE-COMPRESSED 5 MM

